

ECOLOGY & BIODIVERSITY NET GAIN



T 07799 585277
E. info@seven22.co.uk
W. www.seven22.co.uk

Job No. 116
Client: Mr & Mrs Drury
Date: September 2025
Rev:

Location/Description:

Erection of a self-build dwelling on land to side of 26 Stonegate, Spalding, PE11 2PH

Ecology & Biodiversity Net Gain

The applicant is registered on the South Holland District Council Custom and Self-Build register, ref; 5176-4216-6479-3724. This proposal is a self-build project for the applicant and is therefore exempt from the Biodiversity Net Gain criteria. However, it is recognised many bird and bat species as well as hedgehogs that were once common in the UK are now experiencing a decline in numbers, partly due to the loss of habitats.

The proposals include habitats for Swifts in the form of built-in boxes. As Swifts are a colonial breeding species, built-in nests will be placed in pairs approximately 1 metre apart and as high as is possible within this proposal.

Built-in bat boxes will also be provided. Advice from the Bat Conservation Trust states: Boxes should be put as high as possible, ideally at least 4m above ground level, to try and avoid predation from cats on the ground or nearby structures. On buildings, boxes should be placed as close to the eaves as possible and have a sunny aspect.

Please refer to the following details and site layout drawing 116 PO1.

Swift Nest Brick

CODE **GSWB**

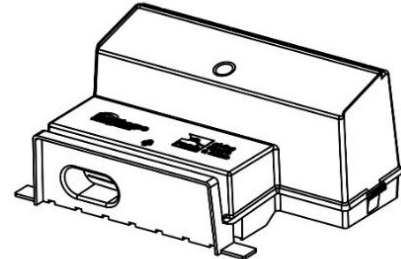
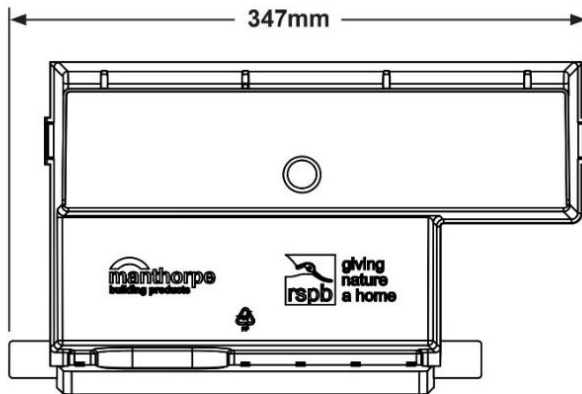

Entrance opening
29 x 65mm

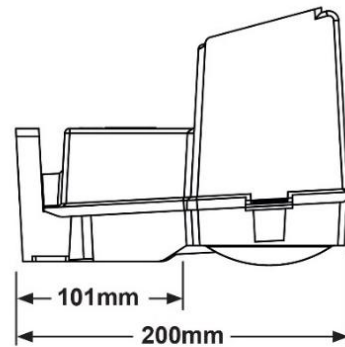
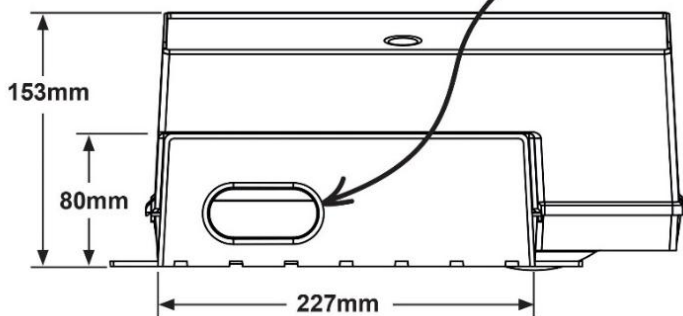

Placement Overview

The Swift Brick should be located high within the gable wall of the property, ideally at 5 metres high and above and over the level of the insulation zone. Where possible, install in locations that are unlikely to receive large amounts of direct sunlight during the hottest times of the day, ideal places include below the overhang of the verge and barge board.

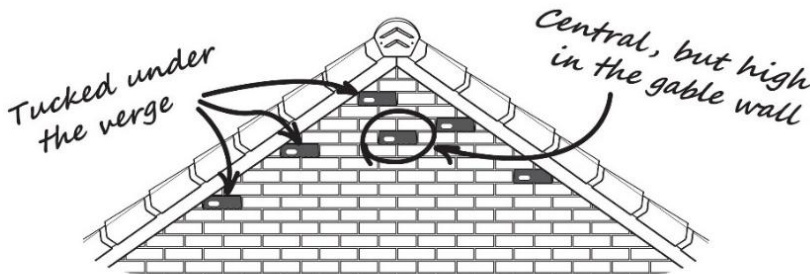

Developed in partnership with



MANTHORPE BUILDING PRODUCTS LTD
MANTHORPE HOUSE
BRITAIN DRIVE
CODNOR GATE BUSINESS PARK
RIPLEY
DERBYSHIRE DE5 3ND

TEL: 01773 303 000
FAX: 01773 303 300
EMAIL:
mbp.care@manthorpebp.co.uk
WEB
www.manthorpebp.co.uk

DRN B.H. Date 20.06.19

The company maintains a policy of continuous development of its product range and reserves the right to amend the specification without notice.

DRG No

MBP 8317

Issue

B
2 of 2

Bats



Ibstock Type B, built in bat box

or

Ibstock Type C, built in bat box

Integrated permanent habitat. Designed specifically for the pipistrelle bat.

Brick slips for type B design would be sourced from site to match development. Type C design in smooth red

A discrete home for bats, the 215 x 215 or 215 x 290 size creates several roosting zones inside the box.

Maintenance free with entrance at the base.

Hedgehogs



The Wildlife Trusts and The British Hedgehog Preservation Society have worked hard to raise awareness of the plight of the British hedgehog over the past two decades. Their simple recommendation of being mindful of the interconnectivity of the landscape will be followed with the inclusion 130x130mm holes within the 'solid' boundaries of the development. The developer will inform the occupiers of the need to maintain these accesses and encourage the creation of habitats within their garden planning.